



NACM 04

Технические характеристики

По вопросам продаж и поддержки обращайтесь:

Архангельск (8182)63-90-72	Калининград (4012)72-03-81	Нижний Новгород (831)429-08-12	Смоленск (4812)29-41-54
Астана +7(7172)727-132	Калуга (4842)92-23-67	Новокузнецк (3843)20-46-81	Сочи (862)225-72-31
Белгород (4722)40-23-64	Кемерово (3842)65-04-62	Новосибирск (383)227-86-73	Ставрополь (8652)20-65-13
Брянск (4832)59-03-52	Киров (8332)68-02-04	Орел (4862)44-53-42	Тверь (4822)63-31-35
Владивосток (423)249-28-31	Краснодар (861)203-40-90	Оренбург (3532)37-68-04	Томск (3822)98-41-53
Волгоград (844)278-03-48	Красноярск (391)204-63-61	Пенза (8412)22-31-16	Тула (4872)74-02-29
Вологда (8172)26-41-59	Курск (4712)77-13-04	Пермь (342)205-81-47	Тюмень (3452)66-21-18
Воронеж (473)204-51-73	Липецк (4742)52-20-81	Ростов-на-Дону (863)308-18-15	Ульяновск (8422)24-23-59
Екатеринбург (343)384-55-89	Магнитогорск (3519)55-03-13	Рязань (4912)46-61-64	Уфа (347)229-48-12
Иваново (4932)77-34-06	Москва (495)268-04-70	Самара (846)206-03-16	Челябинск (351)202-03-61
Ижевск (3412)26-03-58	Мурманск (8152)59-64-93	Санкт-Петербург (812)309-46-40	Череповец (8202)49-02-64
Казань (843)206-01-48	Набережные Челны (8552)20-53-41	Саратов (845)249-38-78	Ярославль (4852)69-52-93



- NACM...04 series
- NENUTEC standard damper actuators are especially designed and produced for applications in the HVAC systems.
- Our wide range of NENUTEC standard damper actuators has been developed to operate and position air dampers of different sizes. Angular positioning of modulating actuators can be controlled by the NPG-1 positioner.

Product Features

- Torque 4 Nm
- Damper size 0.8 m²
- Power Supply AC/DC 24 V
- Control Modulating DC 0...10 V and 0...20 mA
- Shaft dimensions
Ø 6 to 16 mm round / □ 8 to 12 mm square
- Minimum shaft length 50 mm
- Selectable direction of rotation
- Adjustable angle of rotation
- Actuator with cable connection on request
- Customer version on request



Model Selection Table

Torque	Running Time	Power Supply	Auxiliary Switch	Model / Type
4 Nm	25...35 sec	AC/DC 24 V ± 10%	No	NACM 1.2-04
4 Nm	25...35 sec	AC 230 V ± 10%	No	NACM 1.4-04

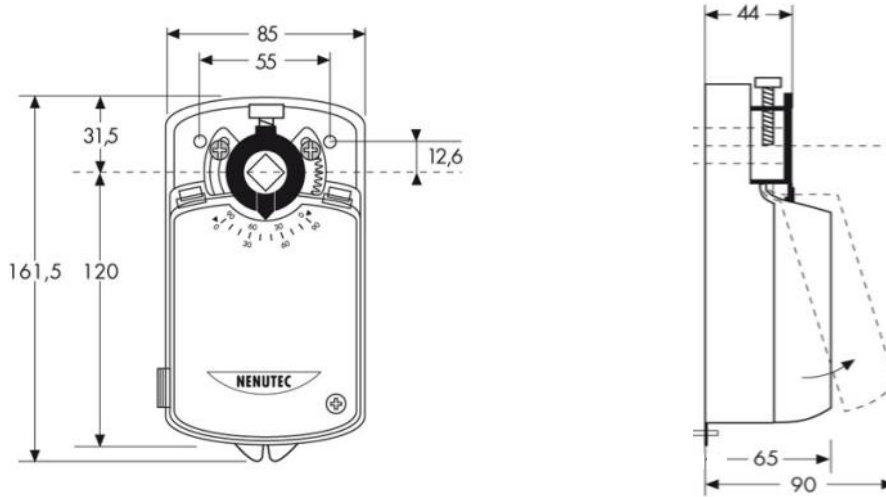
Actuator Dimensions (mm)



Technical Specifications

	NACM 1.2...	NACM 1.4...
Torque	4 Nm	4 Nm
Damper Size	0.8 m ²	0.8 m ²
Shaft dimensions	Ø 6 to 16 mm round / □ 8 to 12 mm square	Ø 6 to 16 mm round / □ 8 to 12 mm square
Power Supply	AC/DC 24 V ± 10%	AC 230 V ± 10%
Frequency	50 - 60 Hz	50 - 60 Hz
Control Signal (Input)	DC 0...10 V	0...20 mA
Position Signal (Output)	DC 0...10 V	DC 0...10 V
Power Consumption		
- Operating	2.0 W	2.0 W
- End Position	0.2 W	0.2 W
For Wire Sizing	4.1 VA	4.1 VA
Protection Class	III 	II 
Angle of Rotation	0°...90° (93° mechanical)	0°...90° (93° mechanical)
Angle of Limiting	0°...90° (max. 0°...30° / 60°...90°)	0°...90° (max. 0°...30° / 60°...90°)
Weight	< 0.9 Kg	< 0.9 Kg
Life Cycle	60'000 rotation	60'000 rotation
Sound Level	50 dB (A)	50 dB (A)
IP Protection	IP 54 (dust protected & protected against splash water)	IP 54 (dust protected & protected against splash water)
Operating Temperature	-20°...+50° C / IEC 721-3-3	-20°...+50° C / IEC 721-3-3
Non-Operating Temperature	-30°...+60° C / IEC 721-3-2	-30°...+60° C / IEC 721-3-2
Ambient Humidity	5%...95% rH non condensing / EN 60730-1	5%...95% rH non condensing / EN 60730-1
Maintenance	Maintenance free	Maintenance free
Mode of Operation	Type I / EN 60730-1	Type I / EN 60730-1
EMC	CE according to 89 / 336 / EEC	CE according to 89 / 336 / EEC

Wiring Diagram NACM 1.2/1.4... Power Supply AC/DC 24 V

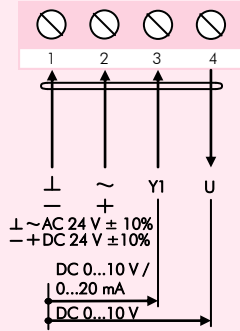

Changing Direction of Rotation NACM 1.2/1.4...

Factory-set CW!

The direction of rotation can be changed by turning the CW/CCW micro switch to the left as far as it will go.

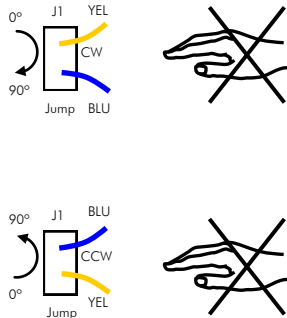
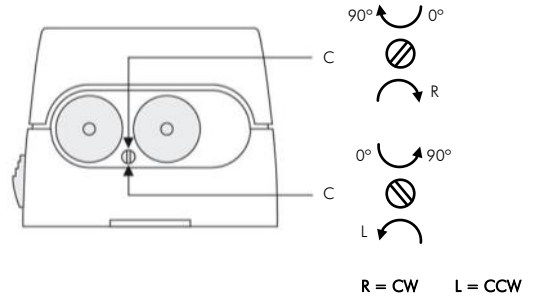

Adjustment of Control Signal NACM 1.2/1.4...

Control signal Y1	DC 0...10 V
Input resistance	Ri 100 kOhm
Control signal Y2	0...20 mA
Input resistance	Ri 500 Ohm
Position signal U	DC 0...10 V
Load resistance	> 50 kOhm

Wiring Diagram NACM 1.2/1.4... Parallel Connection

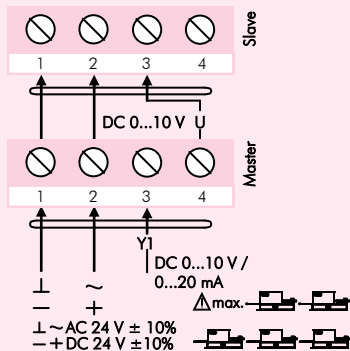

Remark

When NACM... actuators operate in parallel, the output signal $U = DC 0...10 V$ (terminal 4) of the master actuator must be connected to terminal 3 of the next slave actuator.

The power consumption must be observed.



По вопросам продаж и поддержки обращайтесь:

Архангельск (8182)63-90-72	Калининград (4012)72-03-81	Нижний Новгород (831)429-08-12	Смоленск (4812)29-41-54
Астана +7(7172)727-132	Калуга (4842)92-23-67	Новокузнецк (3843)20-46-81	Сочи (862)225-72-31
Белгород (4722)40-23-64	Кемерово (3842)65-04-62	Новосибирск (383)227-86-73	Ставрополь (8652)20-65-13
Брянск (4832)59-03-52	Киров (8332)68-02-04	Орел (4862)44-53-42	Тверь (4822)63-31-35
Владивосток (423)249-28-31	Краснодар (861)203-40-90	Оренбург (3532)37-68-04	Томск (3822)98-41-53
Волгоград (844)278-03-48	Красноярск (391)204-63-61	Пенза (8412)22-31-16	Тула (4872)74-02-29
Вологда (8172)26-41-59	Курск (4712)77-13-04	Пермь (342)205-81-47	Тюмень (3452)66-21-18
Воронеж (473)204-51-73	Липецк (4742)52-20-81	Ростов-на-Дону (863)308-18-15	Ульяновск (8422)24-23-59
Екатеринбург (343)384-55-89	Магнитогорск (3519)55-03-13	Рязань (4912)46-61-64	Уфа (347)229-48-12
Иваново (4932)77-34-06	Москва (495)268-04-70	Самара (846)206-03-16	Челябинск (351)202-03-61
Ижевск (3412)26-03-58	Мурманск (8152)59-64-93	Санкт-Петербург (812)309-46-40	Череповец (8202)49-02-64
Казань (843)206-01-48	Набережные Челны (8552)20-53-41	Саратов (845)249-38-78	Ярославль (4852)69-52-93