



## NAFM 1.2-16

### Технические характеристики

По вопросам продаж и поддержки обращайтесь:

Архангельск (8182)63-90-72	Калининград (4012)72-03-81	Нижний Новгород (831)429-08-12	Смоленск (4812)29-41-54
Астана +7(7172)727-132	Калуга (4842)92-23-67	Новокузнецк (3843)20-46-81	Сочи (862)225-72-31
Белгород (4722)40-23-64	Кемерово (3842)65-04-62	Новосибирск (383)227-86-73	Ставрополь (8652)20-65-13
Брянск (4832)59-03-52	Киров (8332)68-02-04	Орел (4862)44-53-42	Тверь (4822)63-31-35
Владивосток (423)249-28-31	Краснодар (861)203-40-90	Оренбург (3532)37-68-04	Томск (3822)98-41-53
Волгоград (844)278-03-48	Красноярск (391)204-63-61	Пенза (8412)22-31-16	Тула (4872)74-02-29
Вологда (8172)26-41-59	Курск (4712)77-13-04	Пермь (342)205-81-47	Тюмень (3452)66-21-18
Воронеж (473)204-51-73	Липецк (4742)52-20-81	Ростов-на-Дону (863)308-18-15	Ульяновск (8422)24-23-59
Екатеринбург (343)384-55-89	Магнитогорск (3519)55-03-13	Рязань (4912)46-61-64	Уфа (347)229-48-12
Иваново (4932)77-34-06	Москва (495)268-04-70	Самара (846)206-03-16	Челябинск (351)202-03-61
Ижевск (3412)26-03-58	Мурманск (8152)59-64-93	Санкт-Петербург (812)309-46-40	Череповец (8202)49-02-64
Казань (843)206-01-48	Набережные Челны (8552)20-53-41	Саратов (845)249-38-78	Ярославль (4852)69-52-93



The technical specifications might not be congruent.

- NAFM 1.2-16 series
- NENUTEC spring return damper actuators are especially designed and produced for applications in the HVAC systems.
- Our wide range of NENUTEC spring return damper actuators has been developed to operate and position air dampers of different sizes that perform safety functions. Angular positioning of modulating actuators can be controlled by the NPG-1 positioner.

### Product Features

- Torque 16 Nm
- Damper size 3.0 m<sup>2</sup>
- Power Supply AC/DC 24 V
- Control Modulating DC 0...10 V
- Shaft dimensions
  - 10 to 19 mm round / □ 10 to 16 mm square
- Minimum shaft length 20 mm
- Selectable direction of rotation
- Adjustable angle of rotation
- Actuator with 1000 mm cable connection
- Customer version on request

### Model Selection Table

Torque	Running Time	Power Supply	Auxiliary Switches	Model / Type
16 Nm	Ⓜ 150 sec / Ⓞ 16 sec	AC/DC 24 V ± 10%	No	NAFM 1.2-16

## Actuator Dimensions (mm)

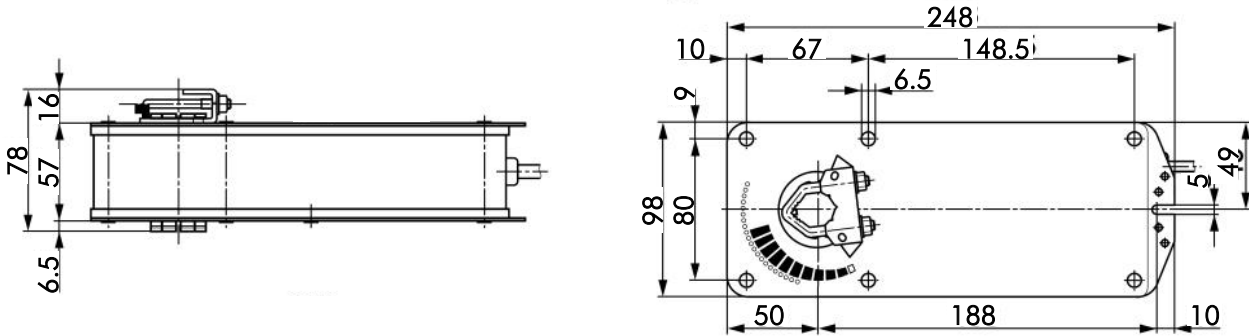

## Technical Specifications

### NAFM 1.2...

Torque $\text{M}$	16 Nm
$\text{C}$	15 Nm
Damper Size	3.0 m <sup>2</sup>
Shaft dimensions	Ø 10 to 19 mm round / □ 10 to 16 mm square
Power Supply	AC/DC 24 V ± 10%
Frequency	50 - 60 Hz
Control Signal (Input)	DC 0...10 V
Operating Range	DC 2...10 V (at control signal Y)
Position Signal (Output)	DC 2...10 V
Power Consumption	
- Operating	6.0 W
- End Position	2.5 W
For Wire Sizing	10.0 VA
Protection Class	III $\text{III}$
Angle of Rotation	0°...90° (-5°...90° mechanical)
Angle of Limiting	0°...45° / 45°...90°
Weight	2.7 Kg
Life Cycle	60'000 rotation
Sound Level	45 dB (A)
IP Protection	IP 54 (dust protected & protected against splash water)
Operating Temperature	-30°...+50° C / IEC 721-3-3
Non-Operating Temperature	-30°...+70° C / IEC 721-3-2
Ambient Humidity	5%...95% rH non condensing / EN 60730-1
Maintenance	Maintenance free
Mode of Operation	Type I / EN 60730-1
EMC	CE according to 89 / 336 / EEC

Wiring Diagram NAFM 1.2...  
Power Supply AC/DC 24 V

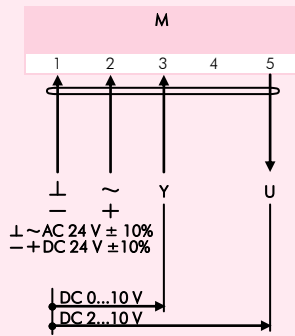

Changing Direction of Rotation NAFM 1.2...

Factory-set CW!

The direction of rotation can be defined dependently on the assembly of the shaft adapter inclusive adapter ring. Important remark:

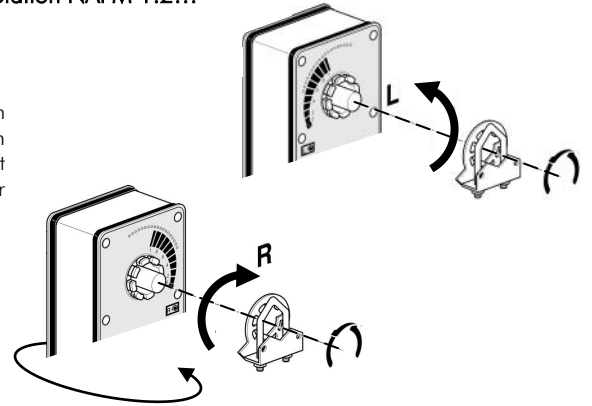
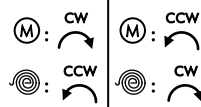

Changing Direction of Rotation NAFM 1.2...

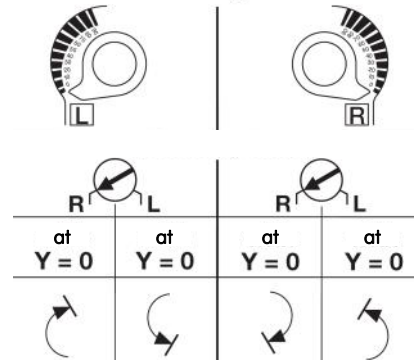

Wiring Diagram NAFM 1.2...  
Parallel Connection

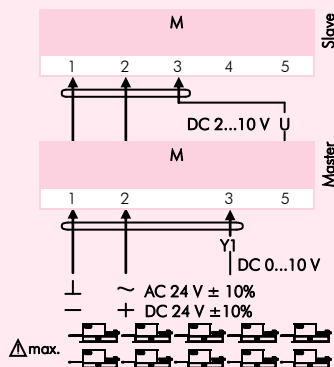

**Remark**

When NAFM... actuators operate in parallel, the output signal U = DC 0...10 V (terminal 5) of the master actuator must be connected to terminal 3 of the next slave actuator.

The power consumption must be observed.

Synchronisation Tolerance ± 5 %



По вопросам продаж и поддержки обращайтесь:

Архангельск (8182)63-90-72	Калининград (4012)72-03-81	Нижний Новгород (831)429-08-12	Смоленск (4812)29-41-54
Астана +7(7172)727-132	Калуга (4842)92-23-67	Новокузнецк (3843)20-46-81	Сочи (862)225-72-31
Белгород (4722)40-23-64	Кемерово (3842)65-04-62	Новосибирск (383)227-86-73	Ставрополь (8652)20-65-13
Брянск (4832)59-03-52	Киров (8332)68-02-04	Орел (4862)44-53-42	Тверь (4822)63-31-35
Владивосток (423)249-28-31	Краснодар (861)203-40-90	Оренбург (3532)37-68-04	Томск (3822)98-41-53
Волгоград (844)278-03-48	Красноярск (391)204-63-61	Пенза (8412)22-31-16	Тула (4872)74-02-29
Вологда (8172)26-41-59	Курск (4712)77-13-04	Пермь (342)205-81-47	Тюмень (3452)66-21-18
Воронеж (473)204-51-73	Липецк (4742)52-20-81	Ростов-на-Дону (863)308-18-15	Ульяновск (8422)24-23-59
Екатеринбург (343)384-55-89	Магнитогорск (3519)55-03-13	Рязань (4912)46-61-64	Уфа (347)229-48-12
Иваново (4932)77-34-06	Москва (495)268-04-70	Самара (846)206-03-16	Челябинск (351)202-03-61
Ижевск (3412)26-03-58	Мурманск (8152)59-64-93	Санкт-Петербург (812)309-46-40	Череповец (8202)49-02-64
Казань (843)206-01-48	Набережные Челны (8552)20-53-41	Саратов (845)249-38-78	Ярославль (4852)69-52-93